

**CITY OF VAN BUREN, ARKANSAS**

**ORDINANCE NO. 10 - 2015**

BE IT ENACTED BY THE CITY COUNCIL, FOR THE CITY OF VAN BUREN, ARKANSAS, AN ORDINANCE TO BE ENTITLED:

**AN ORDINANCE AMENDING ORDINANCE NO. 5-1997, REQUIRING SIDEWALKS IN NEW CONSTRUCTION, REMODELING, RENOVATING AND/OR RECONSTRUCTION OF EXISTING PROPERTY WHEN 50% OR MORE OF THE CRAWFORD COUNTY ASSESSOR'S ASSESSED VALUE OF THE STRUCTURE IS BEING REPLACED OR REMODELED; SETTING SPECIFICATIONS FOR THE SIDEWALKS, AND FOR OTHER PURPOSES.**

WHEREAS, the City of Van Buren desires to require the construction of sidewalks in new residential, commercial, and industrial construction, and remodeling and/or reconstruction of existing properties when 50% or more of the Crawford County Assessor's assessed value of the property is being replaced and/or remodeled; and

WHEREAS, the requirement of sidewalks will protect the health and safety of the residents of the City of Van Buren, Arkansas; and

WHEREAS, the Planning Commission held a public hearing on this issue and voted to recommend this Ordinance to the City Council of the City of Van Buren for approval.

**NOW, THEREFORE, BE IT ORDAINED BY THE CITY COUNCIL OF THE CITY OF VAN BUREN, ARKANSAS, THAT:**

SECTION 1: Sidewalks shall be installed according to city standards and specifications, as adopted by the City Council herein and as amended, along both sides of all streets in all new residential subdivisions, and along one or both sides of all streets, as is applicable, in all other new commercial and industrial development.

SECTION 2: Sidewalks shall be installed when remodeling of existing residential, commercial and industrial structures meet or exceed 50% of the Crawford County Assessor's assessed value of the structure.

SECTION 3: Where exceptional topographic conditions or other extraordinary situations or conditions of a piece of property prohibit sidewalks from being constructed in accordance with city standards and specifications, a variance may be applied for through the Planning Commission in accordance with the procedures for requesting a variance in the Van Buren Zoning Code.

SECTION 4: Previous standards for sidewalks adopted pursuant to Ordinance No. 5-1997 are hereby modified as follows:

Sidewalk Specifications for Van Buren, Arkansas:

- a. All work shall be performed in conformance with the latest American Concrete Institute specifications, the latest Arkansas Fire Prevention Code, and with the attached City of Van Buren sidewalk standard drawings and standard cross-sections.
- b. Concrete: Shall be Portland, having a compression strength of 3,500 lbs. per square inch in 28 days and 3-6% air entrained. No additional water may be added at the job site. An admixture may be added to improve the workability.
- c. Depth: Not less than four (4) inches thick.
- d. Width: Sidewalk shall be a minimum of five (5) feet in width and shall be built inside the city right-of-way. Greenspace shall be within the remaining area between defined sidewalk and curb.
- e. Sub-grade: Sub-soil shall be compacted to 95% standard proctor density or per the approval of the City building inspector. A density test shall be taken at a frequency no less than one (1) per lot or one (1) every eighty (80) linear feet, whichever is greater.
- f. Forming: All forms shall be set vertical, with enough support as not to bulge. Forms and sub-grade shall be thoroughly wetted before placing concrete. Expansion joints shall be ½ inch in width of a rubberized compound the entire depth of the concrete separating each section of sidewalk. Each section of sidewalk shall not exceed 55 feet in length. Control joints shall be cut to a depth of 1/3 the thickness of the concrete. Control joints must be cut using a tool with a minimum of a 1-inch blade. Control joints must be cut during placement and finishing.
- g. Finish: A wooden float will be used to level the concrete. It shall be trowelled smooth, with a light broom finish, broomed perpendicular to the walk to produce a faintly scored surface. All edges shall be edged with an edging tool.
- h. Curing: All concrete shall be wet cured for a minimum of three (3) days, or use an approved curing compound.
- i. Clean-Up: All excess dirt and construction materials shall be removed from the site. The street right-of-way shall be dressed, then sodded, or seeded with grass, as needed.
- j. Approval: Every section of sidewalk shall be inspected by the City Building Inspector or Street Department Superintendent before placing any concrete.
- k. Deviations: Any deviation to the specification contained in this document shall be approved by the City of Van Buren Planning Department.
- l. Time of Construction: Sidewalks for streets interior to a subdivision shall be completed:

- (i) Before the issuance of building permits for eighty percent (80%) of the lots on the block.
- m. Continuity: Sidewalks shall not be installed in such a manner that they conflict with or are obstructed by power lines, telephone poles, fire hydrants, traffic/street signs, mail boxes, trees, buildings, barriers, light poles, or any other structure. Where encroachment is necessary, the minimum unobstructed width of the sidewalk shall be at least four (4) feet. The grades of sidewalks shall be such that abrupt changes of the grades greater than eight percent (8%) are not encountered. When there is an existing or anticipated obstruction, the sidewalk shall be installed around the object and shall provide the required sidewalk width.
- n. Acceptance: Acceptance of the sidewalk section by the City shall be upon issuance of the certificate of occupancy for the structure or the lot where the sidewalk is installed. If multiple lots are purchased from the developer, by one party, but not built upon, sidewalk construction shall be built for each lot.

SECTION 5: The attached City of Van Buren sidewalk standard drawings and standard cross-sections are hereby adopted.

SECTION 6: Any prior ordinances in conflict with the provisions of this Ordinance are hereby repealed. Ordinance No. 5-1997 is not repealed, only modified as set forth specifically herein.

SECTION 7: The various provisions and parts of this Ordinance are hereby declared to be severable, and if any section or part of a section, or any provision or part of a provision herein, is declared to be unconstitutional, inappropriate, or invalid by any court of competent jurisdiction, such holding shall not invalidate or affect the remainder of this Ordinance and to that extent the provisions hereto are declared to be severable.

IN WITNESS WHEREOF, the City of Van Buren, Arkansas, by its City Council, did pass, approve, and adopt, by a vote of 6 for and 0 against the foregoing Ordinance at its regular meeting held on this 17<sup>th</sup> day of August 2015.

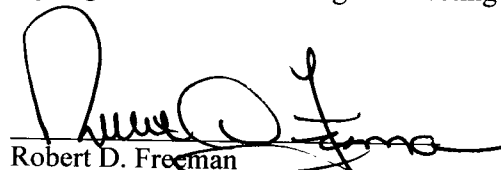
  
Robert D. Freeman  
Mayor

**ATTESTED:**

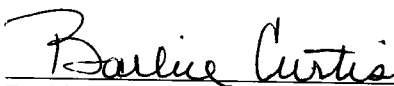
  
Barbie Curtis  
City Clerk/Treasurer

**APPROVED AS TO FORM:**

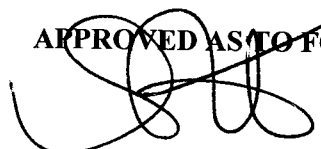
  
Candice A. Settle  
City Attorney



# CITY OF VAN BUREN

## STANDARD CROSS SECTIONS

>>>>>>>PROPOSED<<<<<<<<

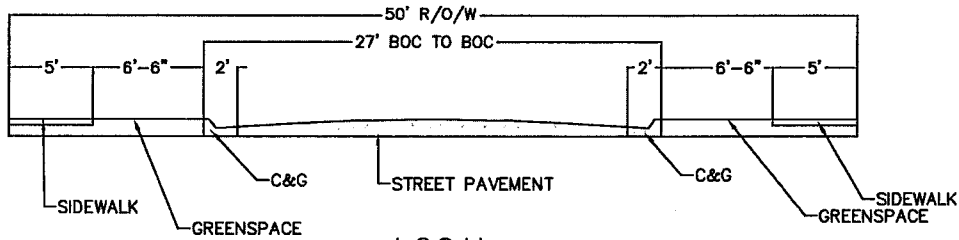

LOCAL  
50' R/O/W  
27' BOC TO BOC  
-NTS-

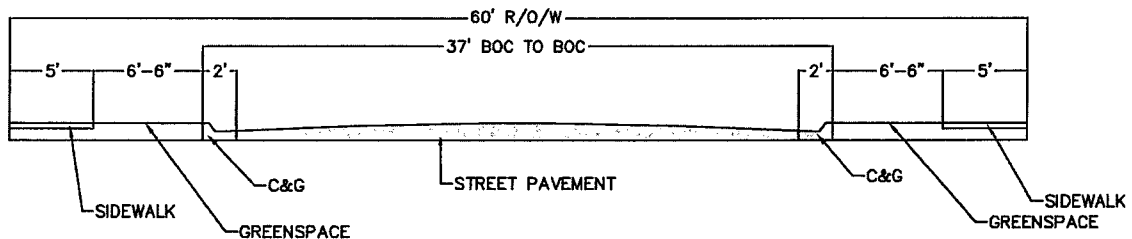

COLLECTOR (CLASS I)  
60' R/O/W  
37' BOC TO BOC  
-NTS-

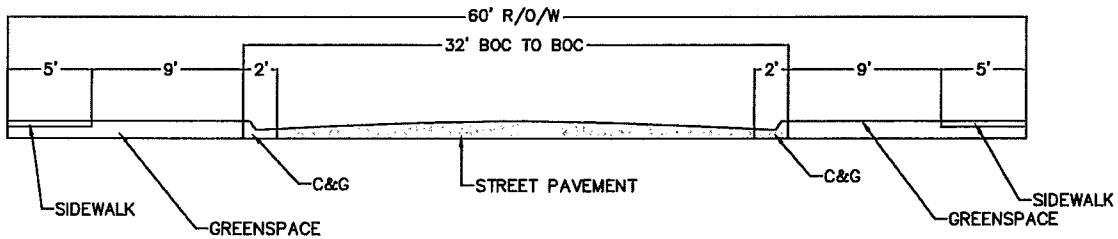

COLLECTOR (CLASS II)  
60' R/O/W  
32' BOC TO BOC  
-NTS-

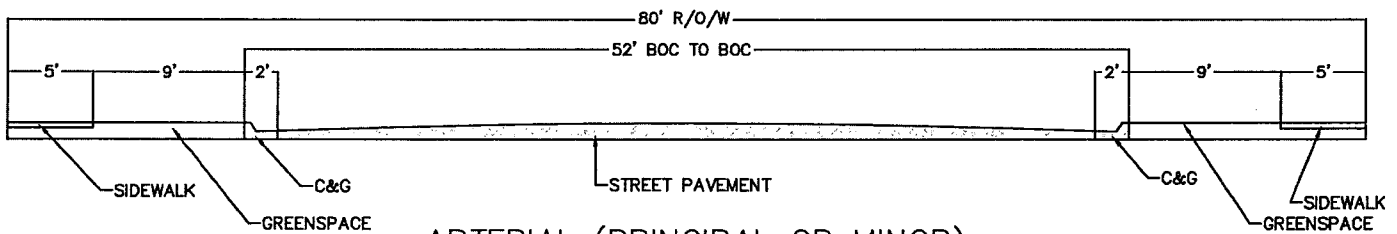

ARTERIAL (PRINCIPAL OR MINOR)  
80' R/O/W  
52' BOC TO BOC  
-NTS-





- NOTES:
1. ALL CONCRETE SHALL BE CLASS "A", 5000 PSI, AIR-ENHANCED, 3-4% AND INTERLOCK FOR RAMP AND SIDEWALK CONSTRUCTION IS TO BE PER AND COMPLIANT TO A MINIMUM OF SIX THICKNESS PROTECTORS.
  2. 1/2" EXPANSION JOINT SHALL BE PLACED AT 10' INTERVALS AT CONSTRUCTION JOINTS SHALL BE CUT AT INTERVALS HAVING THE SAME PERIODICITY AS THE JOINTS. DEPTH OF JOINTS SHALL BE EQUAL TO 1/4".
  3. TYPE OF HANDICAP RAMP IDENTIFIED FOR EACH SITE MAY VARY AND CONSTRUCTION OF RAMP SHALL BE IN ACCORDANCE WITH THE SPECIFICATIONS AND NOTES TO THE DRAWING.
  4. TYPE 1 RAMP SHALL BE USED ONLY IF EXISTING CONDITIONS PREVENT USE OF TYPE 2 RAMP.
  5. ADDITIONAL REMOVALS OUTSIDE THE LIMITS SHOWN MAY BE REQUIRED AS NECESSARY TO OBTAIN THE GRADE FOR RAMP OR PROVIDE LANDING AREAS.
  6. THE LENGTH OF THE RAMP SHALL BE SUCH THAT THE SLOPE DOES NOT EXCEED 1:12. THE SLOPE SHALL BE 1:12 UNLESS OTHERWISE NOTED.
  7. THE RAMP SHALL BE CONSTRUCTED TO PROVIDE ACCESS TO THE RAMP AND TO BE CONFORMANT WITH THE ADA. THE RAMP SHALL BE CONSTRUCTED TO PROVIDE ACCESS TO THE RAMP AND TO BE CONFORMANT WITH THE ADA. THE RAMP SHALL BE CONSTRUCTED TO PROVIDE ACCESS TO THE RAMP AND TO BE CONFORMANT WITH THE ADA.
  8. THE NUMBER WIDTH OF THE RAMP SHALL BE THE EXISTING WALK WIDTH MINUS 36" MINUS 18" MINUS 9" EQUALS 9".
  9. THE SURFACE TEXTURE OF ALL RAMPS SHALL BE BROOK FINISHED EXCEPT FOR AREAS WITH DETECTABLE MARKING DEVICE.
  10. THE NORMAL CUTTER GRADE SHALL BE MAINTAINED THROUGH THE AREA OF THE RAMP.
  11. A SAW-CUT TO A MINIMUM DEPTH OF 2 INCHES SHALL BE MADE PRIOR TO REPAIRING OR CONCRETE REPAIR, 1" SLOPE OR MORE.
  12. FOR RECONSTRUCTION PROJECTS, IF EXISTING CURB & GUTTER IS IN GOOD CONDITION, CURB SHALL BE SHOWN AT CUTTER LOCATION AND REBUILT.
  13. FOR EXISTING PROJECTS, SIDEWALKS WITHIN THE RAMP AREA WILL BE REBUILT BY EXISTING CONTRACTOR. SIDEWALKS WITHIN THE RAMP AREA WILL BE REBUILT BY EXISTING CONTRACTOR. SIDEWALKS WITHIN THE RAMP AREA WILL BE REBUILT BY EXISTING CONTRACTOR.
  14. FOR EXISTING PROJECTS, SIDEWALKS WITHIN THE RAMP AREA WILL BE REBUILT BY EXISTING CONTRACTOR. SIDEWALKS WITHIN THE RAMP AREA WILL BE REBUILT BY EXISTING CONTRACTOR. SIDEWALKS WITHIN THE RAMP AREA WILL BE REBUILT BY EXISTING CONTRACTOR.

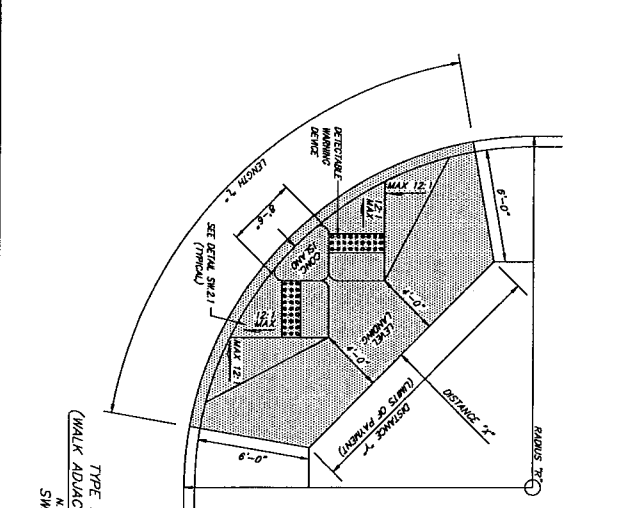
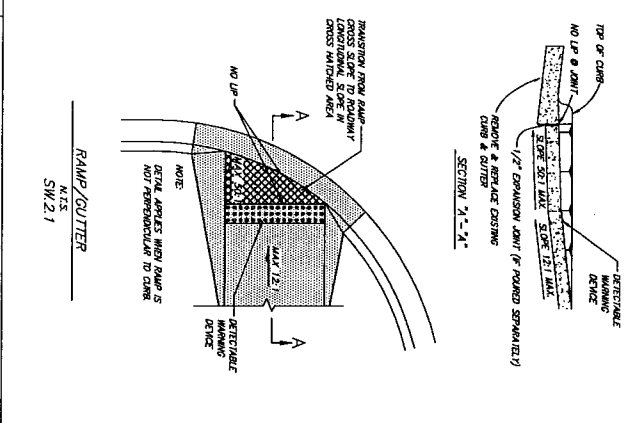
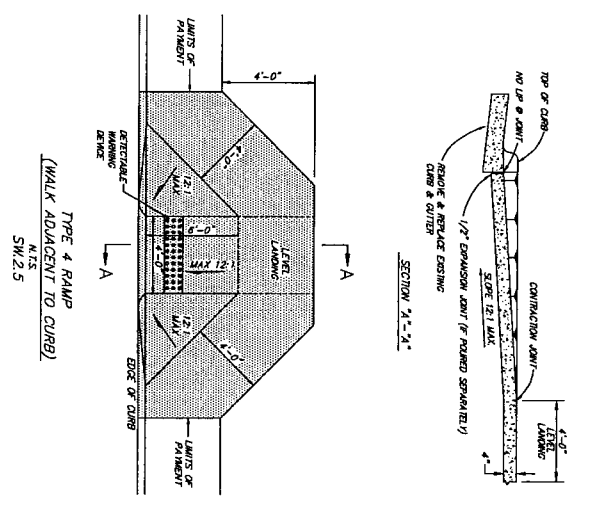
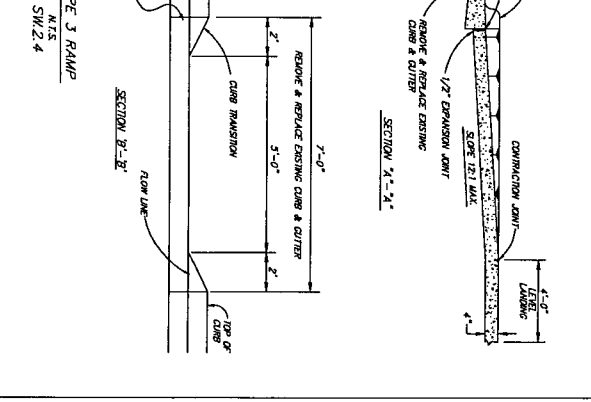
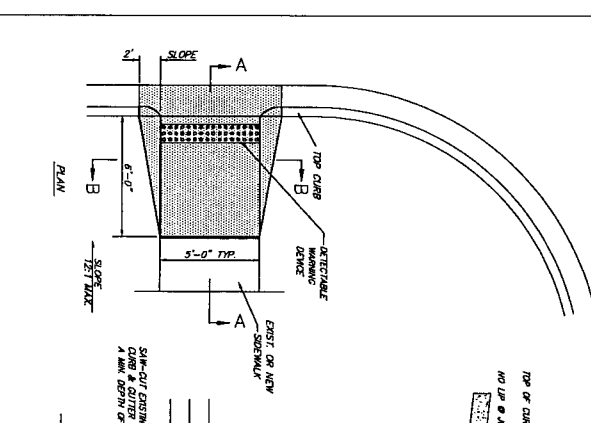
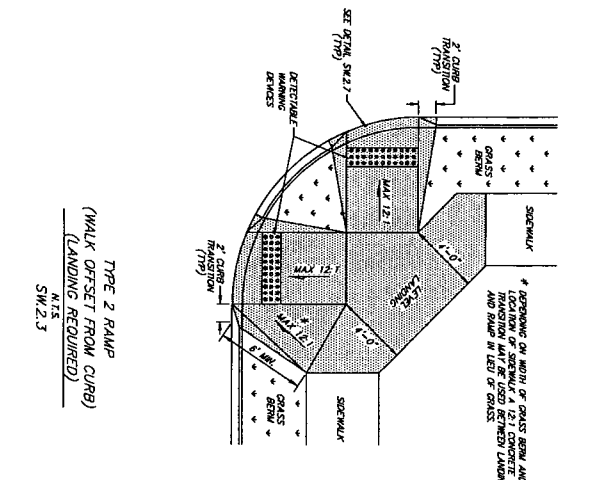

TYPE 1 RAMP DIMENSIONS AND QUANTITIES

RADIUS	DISTANCE	DISTANCE	LENGTH	RAMP AREA
FEET	FEET	FEET	FEET	SQ. YD.
15	11.67	18.82	32.16	28.21
20	11.92	22.28	35.46	30.07
25	11.27	26.60	40.83	36.80
30	11.23	30.26	43.11	39.72
40	11.20	36.43	45.28	42.43
45	11.27	39.16	47.38	44.97
50	11.25	41.89	48.38	47.35
55	11.24	44.07	51.37	49.63
60	11.22	46.33	53.27	51.60

NOTE: HATCHED AREA 1/4" DENOTES CONCRETE REED FOR ONE TYPE 1 RAMP (SQUARE YARDS)

Revision	Date	BY

Project:	04818
Date:	APR 2015
Scale:	As Shown
Drawn By:	RRB
Dep. No.:	SW2
Sheet No.:	2